

Dynapac DRP45DX

Plate compactors



Technical data



Masses

Basic mass	455 kg
Operating mass (W)	460 kg
Operating mass (W1)	440 kg
Operating mass (W2)	453 kg
Operating mass (W3)	471 kg



Traction

Max. gradeability	35 %
Max. working speed	28 m/min



Compaction

Frequency	66 Hz
Centrifugal force	60 kN
Amplitude	1.96 mm



Engine

Manufacturer/Model	Hatz 1B 40
Emissions according to	non EPA or US T4f
Type	Air cooled diesel
Number of cylinders	1
Fuel consumption /h, avg.	1.5 l
Fuel tank capacity	5 l
Power	6.7 kW @ 3000 rpm



Drive system

Drive system	Mechanical
--------------	------------

Find us locally at www.dynapac.com

We reserve the right to change specifications without notice. Photos and illustrations do not always show standard versions of machines. The above information is a general description only, all informations are supplied without liability.

Dynapac DRP45DX

Plate compactors



Technical data

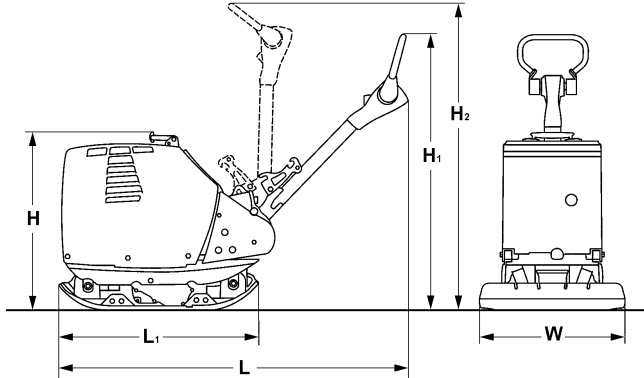

Dimensions	
H. Height	790 mm
H1. Height	980 mm
H2. Height	1380 mm
L. Length	1700 mm
L1. Length	900 mm
W. Basic plate width	650 mm (100 + 450 + 100)
W1. Plate width, without extensions	450 mm
W2. Plate width, with extensions	550 mm (50 + 450 + 50)
W3. Plate width, with extensions	750 mm (150 + 450 + 150)



Standard equipment

- Control handle -comfort -with vibration isolation
- Height adjustable control lever
- Control lever lock in transport and working position
- Reverse drive protection
- Highly wear resistant base plate
- All around protection hood
- All around protection for V-belt
- Automatic decompression
- One point lift
- Recoil starter
- Electric starter
- Hour meter



Optional equipment

- Block paving mat
- Extension plate
- Service Kit

Find us locally at www.dynapac.com

We reserve the right to change specifications without notice. Photos and illustrations do not always show standard versions of machines. The above information is a general description only, all informations are supplied without liability.