

# Dynapac DRP60D

## Plate compactors



### Technical data



#### Masses

Basic mass	560 kg
Operating mass (W)	570 kg
Operating mass (W1)	547 kg
Operating mass (W2)	585 kg



#### Traction

Max. gradeability	35 %
Max. working speed	28 m/min



#### Compaction

Frequency	66 Hz
Centrifugal force	70 kN
Amplitude	1.80 mm



#### Engine

Manufacturer/Model	Hatz 1D 81
Emissions according to	Stage V /non EPA
Type	Air cooled, diesel
Number of cylinders	1
Fuel consumption /h, avg.	2.0 l
Fuel tank capacity	10 l
Power	9.3 kW @ 2700 rpm



#### Drive system

Drive system	Mechanical
--------------	------------

Find us locally at [www.dynapac.com](http://www.dynapac.com)

We reserve the right to change specifications without notice. Photos and illustrations do not always show standard versions of machines. The above information is a general description only, all informations are supplied without liability.

dynapac\_drp60d\_en-20191111.095824.pdf 2019-11-11 09:58

# Dynapac DRP60D

## Plate compactors



### Technical data

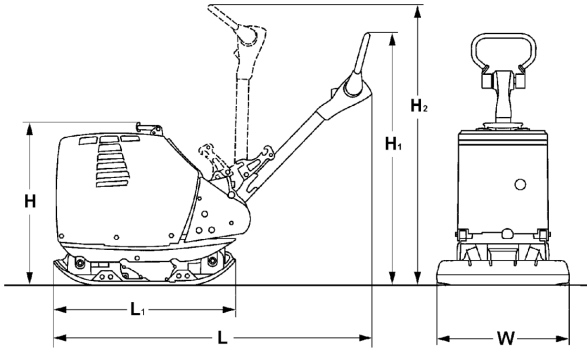

Dimensions	
H. Height	910 mm
H1. Height	1180 mm
H2. Height	1540 mm
L. Length	1860 mm
L1. Length	980 mm
W. Basic plate width	700 mm (75 + 550 + 75)
W1. Plate width, without extensions	550 mm
W2. Plate width, with extensions	850 mm (150 + 550 + 150)



#### Standard equipment

- Control handle -comfort -with vibration isolation
- Height adjustable control lever
- Control lever lock in transport and working position
- Reverse drive protection
- Highly wear resistant base plate
- All around protection hood
- All around protection for V-belt
- Automatic shutdown at low oil level
- One point lift
- Electric starter
- Hour meter



#### Optional equipment

- Crank start handle (+3kg)
- Block paving mat
- Extension plate
- Service Kit

Find us locally at [www.dynapac.com](http://www.dynapac.com)

We reserve the right to change specifications without notice. Photos and illustrations do not always show standard versions of machines.  
The above information is a general description only, all informations are supplied without liability.