

Dynapac DRQ25

Reversible plates



LONGEVITY

- Wear resistance characteristics of HARDOX maximizes the life-time of the base-plate.
- Open-style construction of the base-plate prevents the stones from getting stuck, thus reducing the wear & tear.

DURABILITY

- Robust all-around protection cage with solid one-point lift.

COMFORT

- Low levels of hand arm vibration is made possible by the vibration damping solution.

PRACTICAL

- Easy-open flaps to access daily check points like fuel tank cap, filter.

Technical data



Masses

Basic mass	238 kg
Operating mass	240 kg



Traction

Max. gradeability	20 %
Max. working speed	25 m/min



Compaction

Amplitude	1.7 mm
Centrifugal force	38 kN
Frequency	78 Hz



Engine

Manufacturer/Model	Honda GX 200
Emissions according to	EU Stage V & US EPA
Type	Air cooled, petrol
Number of cylinders	1
Fuel consumption /h, avg.	1.50 l
Fuel tank capacity	3.10 l
Power	4.3 kW @ 3600 rpm



Drive system

Drive system	Mechanical
--------------	------------

Find us locally at www.dynapac.com

We reserve the right to change specifications without notice. Photos and illustrations do not always show standard versions of machines. The above information is a general description only, all informations are supplied without liability.

Dynapac DRQ25

Reversible plates

Technical data

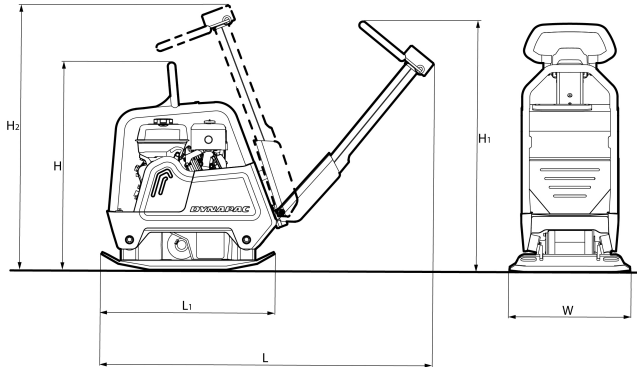

Dimensions	
H. Height	935mm
H1. Height	1110mm
H2. Height	1200mm
L. Length	1540mm
L1. Length	785mm
W. Basic plate width	500mm



Standard equipment

- Control handle -comfort -with vibration isolation
- Height adjustable control lever
- Control lever lock in transport position
- Reverse drive protection
- Highly wear resistant hardox base plate
- Protection hood
- All around protection for V-belt
- One point lift
- Recoil starter



Optional equipment

- Block paving mat
- Service Kit

Find us locally at www.dynapac.com

We reserve the right to change specifications without notice. Photos and illustrations do not always show standard versions of machines. The above information is a general description only, all informations are supplied without liability.