

MOVING YOU FURTHER

Robex 60-95

With Tier 2 Engine installed



*Photo may include optional equipment.

- * Standard and optional equipment may vary. Contact your Hyundai dealer for more information. The machine may vary according to International standards.
- * The photos may include attachments and optional equipment that are not available in your area.
- * Materials and specifications are subject to change without advance notice.
- * All imperial measurements rounded off to the nearest pound or inch.

PLEASE CONTACT

 **HYUNDAI CONSTRUCTION EQUIPMENT**

Pride at Work

Hyundai Construction Equipment strives to build state-of-the-art earthmoving equipment to give every operator maximum performance, more precision, versatile machine preferences, and proven quality. Take pride in your work with Hyundai!

Robex 60-9S

Machine Walk-Around

Rugged Upper and Lower Frame

The upper frame is designed with optimum structural integrity to absorb impact and operational stress. The x-style center frame and reinforced box section track frame provide exceptional strength and longer service life to withstand tough working conditions.

Engine Technology

The fuel efficient, Tier 2 certified Yanmar 4TNV94L engine provides proven, reliable power.

Efficient Control System

All control devices are arranged for higher productivity and improved operator comfort. Efficient and ergonomic controls allow an operator to control the machine in any working environment. A safety lever on the left-side console is provided to prevent exiting the cabin while hydraulic controls are live.

Advanced Hydraulic System

The advanced hydraulic system includes an arm flow summation system, boom holding system and a swing parking brake for smooth and fine control. Other valuable features include a hydraulic damper in the travel pedal, and a hydraulically lubricated swing reducer with a leak-free grease chamber.

Comfortable and Durable Cabin

The cabin is roomy and ergonomically designed, for reduced noise and good visibility. The cabin frame meets international standard TOPS, FOPS ensuring operator safety.

Operator Convenience

Convenient operator features include a suspension seat, excellent visibility, and variable storage space for advanced operator comfort. The newly designed LED cluster provides current information, including engine RPM, engine coolant, fuel level, and electric components. A hydraulic function safety lock and auto diagnostic features are also available. Lock and failure diagnosis functions are also integrated.

A powerful air conditioning system and Radio/USB interface contribute to a comfortable work environment.

Easy and Simple Maintenance

Wide open access of doors, covers, hoods is designed for easier maintenance. The air cleaner and centralized grease fittings are also integrated for easy service.

Extended Life of Components

Long life components and wear parts, including hydraulic filters, oil, shims, and bushings, help to reduce operating costs.



*Photo may include optional equipment.

Preference



*Photo may include optional equipment.

Operator Comfort

The R60-9S operator's cab is designed for a comfortable operating experience. An ergonomically designed suspension seat, adjustable arm rests and a spacious environment helps to minimize operator fatigue. Control levers are easily accessible and an instrument display is provided to keep the operator informed of pertinent machine information.

1. A large upper roof glass provides additional visibility and a roller shade is provided to reduce glare and sunlight.
2. An advanced audio system with AM/FM stereo with USB player, plus remotely located control is perfect for listening to music favorites.
3. A hands-free cell phone function is available for safe and convenient phone use.
4. Ergonomically designed joysticks reduce operator fatigue during the work day.
5. Multiple storage compartments are available for additional convenience.



1 Roller shade 2 Radio & USB player with remote control 3 Hands-free cell phone 4 Joystick 5 Storage compartment

Enhanced Cabin

Hyundai's R60-9S is equipped for convenience and productivity.

1. Adjustable position window prevents window movement while operating.
2. A sliding fold-in front window is easily opened and safely stored in an open position to improve ventilation and visibility.
3. A tilt-up left side control console provides easier entrance and exit from the cab.
4. A power climate control system provides the operator with optimum air temperature.



1 Adjustable side window 2 Sliding fold-in front window 3 Tilt-up control console 4 Climate control system



Operator - Friendly Cluster

The advanced new LED cluster allows the operator to select his personal machine preferences. The monitor displays engine rpm, engine oil temperature, water temperature and information for all electronic devices. Button selections are provided for auto idle mode, max power mode, and travel speed. A security feature is also provided to prevent the machine from starting without a proper password.

Wide Cabin with Excellent Visibility

The newly designed cabin was conceived for more space, a wider field of view and operator comfort. Special attention was given to a clear, open and convenient interior with plenty of visibility on the machine surroundings and the job at hand. This well balanced combination of precision aspects put the operator in the perfect position to work safely and securely.



Precision & Performance

Innovative hydraulic system technologies make the R60-9S excavator fast, smooth and easy to control. Also R60-9S is designed for maximum performance to keep the operator working productively.



*Photo may include optional equipment.

Excellent Performance

Hyundai's 9S series offers the operator maximized productivity and efficiency. A convenient throttle volume dial with LED light allows the operator to customize engine power according to job requirements. A max power button maximizes machine speed and power for mass production.

The R60-9S also features an auto idle system which improves fuel efficiency and reduces cab noise.

Improved Hydraulic System



To achieve optimum precision, Hyundai redesigned the hydraulic system to provide the operator with super fine touch and improved controllability. Improved pump flow control reduces flow when controls are not being used to minimize fuel consumption. Improved spool valves in the control valve are engineered to provide more precise flow to each function with less effort. Improved hydraulic valves, precision-designed variable volume piston pumps, fine-touch pilot controls, and enhanced travel functions make any operator running a 9S series look like a smooth operator. Boom-down flow regeneration and control valve technology are newly improved.

Variable Swing Boom (Option)

The R60-9S's boom swing function is designed for efficient work in congested residential and urban areas. The boom can be offset left or right within an operating range. Plus, increased swing torque provides enhanced operating capability on the slope.

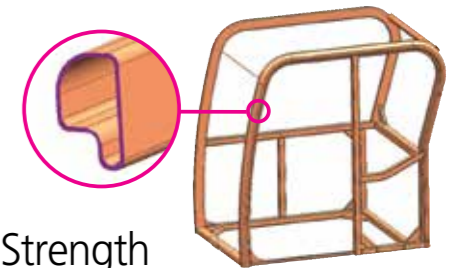

Structure Strength

The 9S series cabin structure has been fitted with stronger but slimmer tubing for more safety and improved visibility. Low-stress, high strength steel is integrally welded to form a stronger, more durable upper and lower frame. Structural integrity was tested by way of FEM (Finite Elements Method) analysis and long-term durability tests.



Yanmar 4TNV94L

The Highest Engine Power in its Class

Yanmar 4TNV94L engine provides 20.6 kgf-m (149 lbf-ft) of maximum torque with 53 HP at 2,200rpm of rated power. This means the R60-9S runs with the most power in its class, giving you more power to get the job done.

Profitability

R60-9S is designed to maximize profitability through improved efficiencies, enhanced service features and longer life components.



*Photo may include optional equipment.

Fuel Efficient

9S series compact excavators are engineered to be extremely fuel efficient. A newly applied cooling fan clutch contributes to reduced noise and improved fuel efficiency.



Improved Durability

The R60-9S is equipped with counterweight rear guards to protect the engine hood. Attachment pin with lock-nut type prevents deformation of boom lug and reduces the side play at the boom to arm connection for a long life.



Easy Access

Centralized grease fittings and easy change plastic air cleaner provide faster, easier service and maintenance.



Wide Open Engine hood

A newly designed full-open type engine hood makes service more convenient on the R60-9S.



Extended Life Components

The 9S series is designed for longer lubrication intervals and extended component life. Hydraulic oil can last up to 5,000 hours before changing. Also, a new center pivot roller bearing design, now double tapered, requires less maintenance as well. Long life and extended wear components save the operator time and money.

Specifications

ENGINE

MODEL		YANMAR 4TNV94L	
Type	Water cooled, 4 cycle diesel 4 cylinders in line, direct injection, low emission		
Rated flywheel horsepower	SAE	J1995 (gross)	53 HP (40 kW) at 2,200 rpm
		J1349 (net)	52 HP (39 kW) at 2,200 rpm
	DIN	6271/1 (gross)	54 PS (40 kW) at 2,200 rpm
		6271/1 (net)	53 PS (39 kW) at 2,200 rpm
Max. torque	20.6 kgf·m (149 lbf·ft) at 1,400 rpm		
Bore X stroke	94 mm (3.7") x 110 mm (4.33")		
Piston displacement	3,054 cc (186 cu in)		
Batteries	1 x 12 V x 100 AH		
Starting motor	12 V, 3.0 kW		
Alternator	12 V, 100 Amp		

HYDRAULIC SYSTEM

MAIN PUMP	
Type	Variable displacement piston pump
Max. flow	2 X 55 + 36.6ℓ/min (2 X 14.5 + 9.7 US gpm / 2 X 12.1 + 8.1 UK gpm)
Sub-pump for pilot circuit	Gear pump

Cross-sensing and fuel saving pump system

HYDRAULIC MOTORS	
Travel	Two speed axial piston motor with counter balance valve and parking brake
Swing	Axial piston motor with automatic brake

RELIEF VALVE SETTING	
Implement circuits	220 kgf/cm ²
Travel circuit	220 kgf/cm ²
Swing circuit	220 kgf/cm ²
Pilot circuit	30 kgf/cm ²
Service valve	Installed

HYDRAULIC CYLINDERS	
No. of cylinder bore X stroke	Boom: 1-110 x 715 mm
	Arm: 1-90 x 850 mm
	Bucket: 1-80 x 660 mm
	Boom swing: 1-95 x 527 mm
	Dozer blade: 1-110 x 224 mm

TRAVEL SYSTEM

Drive method	Full hydrostatic type
Drive motor	Axial piston motor, in-shoe design
Reduction system	Planetary reduction gear
Max. drawbar pull	5,300 kgf
Max. travel speed(high) / (low)	4.0 km/hr / 2.2 km/hr
Gradeability	35° (70%)
Parking brake	Multi-wet disc

CONTROLS

Pilot pressure operated joysticks and pedals with detachable lever provide almost effortless and fatigueless operation.

Pilot control	Two joysticks with one safety lever (LH): Arm swing, Boom swing (RH): Boom and bucket (ISO)
Traveling and steering	Two levers with pedals
Engine throttle	Cabin(Dual type), E/G(Mechanical)

SWING SYSTEM

Swing motor	Axial piston motor
Swing reduction	Planetary gear reduction
Swing bearing lubrication	Grease-bathed
Swing brake	Multi wet disc
Swing speed	9.2 rpm

COOLANT & LUBRICANT CAPACITY

(Refilling)	liter	US gal	UK gal
Fuel tank	125.0	33.0	27.5
Engine coolant	9.5	2.5	2.1
Engine oil	11.6	3.1	2.6
Swing device-gear oil	1.5	0.4	0.3
Final drive(each)	1.2	0.3	0.3
Hydraulic tank	70.0	18.5	15.4
Hydraulic system	120.0	31.7	26.4

UNDERCARRIAGE

X-leg type center frame is integrally welded with reinforced box-section track frames. The undercarriage includes lubricate rollers, track adjusters with shock absorbing springs and sprockets, and track chain with triple grouser shoes.

Center frame	X - leg type
Track frame	Pentagonal box type
No. of track shoe on each side	40
No. of upper roller on each side	1
No. of lower roller on each side	5

OPERATING WEIGHT (APPROXIMATE)

Operating weight, including 3,000 mm boom, 1,600 mm arm, SAE heaped 0.18 m³ digging bucket, lubricant, coolant, full fuel tank, hydraulic tank and the standard equipment.

MAJOR COMPONENT WEIGHT	
Upperstructure	2,710 kg
Mono boom(with arm cylinder)	310 kg
OPERATING WEIGHT	
Operating weight	5,650 kg

·Mono boom with blade

Specifications

BUCKETS

Capacity		Width		Weight
SAE heaped	CECE heaped	Without side cutters	With side cutters	
0.07 m ³	0.06 m ³	315 mm	360 mm	115 kg
0.18 m ³	0.15 m ³	670 mm	740 mm	170 kg
◆ 0.18 m ³	0.15 m ³	610 mm	740 mm	170 kg

DIGGING FORCE

Arm	Length	1,600 mm	1,900 mm
	Weight	210 kg	230 kg
Bucket digging force	SAE	37.7 kN	37.7 kN
		3,850 kgf	3,850 kgf
	ISO	8,490 lbf	8,490 lbf
		42.4 kN	42.4 kN
Arm crowd force	SAE	4,330 kgf	4,330 kgf
		9,550 lbf	9,550 lbf
	ISO	28.4 kN	25.5 kN
		2,900 kgf	2,600 kgf
Arm crowd force	SAE	6,390 lbf	5,730 lbf
		31.9 kN	28.7 kN
	ISO	3,260 kgf	2,930 kgf
		7,190 lbf	6,460 lbf

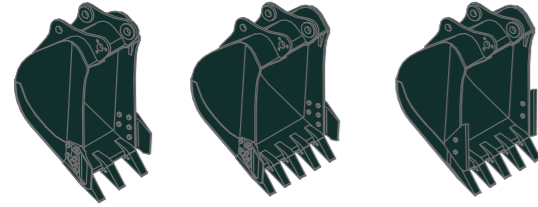

SAE heaped 0.07 m³ 0.18 m³ ◆ 0.18 m³

◆ Heavy duty bucket

*Arm weight including cylinder and linkage.

Lifting Capacity

R60-9S

Rating over-front Rating over-side or 360 degree

Boom : 3.0m / Arm : 1.6 m / Bucket : 0.18m³ SAE heaped / Dozer blade down

Load point height (m)	kg	Load radius						At max. reach		Reach (m)		
		2.0 m		3.0 m		4.0 m		5.0 m			Capacity	
5.0 m	kg									*950	*950	4.12
4.0 m	kg					*1020	*1020			*980	780	5.08
3.0 m	kg					*1090	*1090			*1010	650	5.60
2.0 m	kg	*3050	*3050	*1690	*1690	*1320	1100	*1170	760	*1050	590	5.84
1.0 m	kg			*2360	1610	*1600	1040	*1280	740	*1100	580	5.85
Ground	kg	*2350	*2350	*2700	1540	*1790	1000	*1350	720	*1140	610	5.63
-1.0 m	kg	*3600	3020	*2670	1530	*1800	990			*1180	700	5.13
-2.0 m	kg	*3770	3060	*2300	1540					*1140	960	4.23
-3.0 m	kg	*2040	*2040									

1. Lifting capacity is based on SAE J1097, ISO 10567.

2. Lifting capacity of the Robex Series does not exceed 75% of the tipping load with the machine on firm, level ground or 87% of full hydraulic capacity.

3. The load point is a hook located on the back of the bucket.

4. (*) indicates the load limited by hydraulic capacity.

Lifting Capacity

R60-9S

Rating over-front Rating over-side or 360 degree

Boom : 3.0m / Arm : 1.6 m / Bucket : 0.18m³ SAE heaped / Dozer blade up

Load point height (m)	kg	Load radius						At max. reach		Reach (m)		
		2.0 m		3.0 m		4.0 m		5.0 m			Capacity	
5.0 m	kg									*950	*950	4.12
4.0 m	kg							*1020	*1020	*980	740	5.08
3.0 m	kg							*1090	1080	890	610	5.60
2.0 m	kg	*3050	*3050	*1690	1630	*1320	1030	1040	710	810	550	5.84
1.0 m	kg			2250	1510	1430	980	1010	690	800	540	5.85
Ground Line	kg	*2350	*2350	2170	1440	1390	940	990	670	840	570	5.63
-1.0 m	kg	*3600	2780	2150	1420	1370	930			970	660	5.13
-2.0 m	kg	*3770	2830	2170	1440					*1140	900	4.23
-3.0 m	kg	*2040	*2040									

Boom : 3.0m / Arm : 1.9 m / Bucket : 0.18m³ SAE heaped / Dozer blade down

Load point height (m)	kg	Load radius						At max. reach		Reach (m)		
		2.0 m		3.0 m		4.0 m		5.0 m			Capacity	
5.0 m	kg									*870	*870	4.58
4.0 m	kg									*900	700	5.43
3.0 m	kg							*950	*950	*990	780	5.91
2.0 m	kg			*1440	*1440	*1190	1110	*1080	760	*970	540	6.13
1.0 m	kg	*2050	*2050	*2160	1630	*1500	1050	*1220	740	*1020	530	6.14
Ground Line	kg	*2280	*2280	*2610	1540	*1730	1000	*1320	710	*1060	550	5.93
-1.0 m	kg	*3230	2980	*2700	1510	*1810	980	*1310	700	*1100	620	5.48
-2.0 m	kg	*4140	3020	*2450	1520	*1630	980			*1100	810	4.67
-3.0 m	kg	*2760	*2760	*1640	1570							

Boom : 3.0m / Arm : 1.9 m / Bucket : 0.18m³ SAE heaped / Dozer blade up

Load point height (m)	kg	Load radius						At max. reach		Reach (m)		
		2.0 m		3.0 m		4.0 m		5.0 m			Capacity	
5.0 m	kg									*870	*870	4.58
4.0 m	kg									*900	660	5.43
3.0 m	kg							*950	*950	*990	740	5.91
2.0 m	kg			*1440	*1440	*1190	1040	1040	720	750	500	6.13
1.0 m	kg	*2050	*2050	*2160	1530	1440	980	1010	690	740	490	6.14
Ground Line	kg	*2280	*2280	2170	1440	1390	940	990	670	770	510	5.93
-1.0 m	kg	*3230	2740	2140	1410	1360	910	980	660	870	580	5.48
-2.0 m	kg	*4140	2780	2150	1420	1370	920			*1100	760	4.67
-3.0 m	kg	*2760	*2760	*1640	1470							

1. Lifting capacity is based on ISO 10567.

2. Lifting capacity of the Robex Series does not exceed 75% of the tipping load with the machine on firm, level ground or 87% of full hydraulic capacity.

3. The load point is a hook located on the back of the bucket.

4. (*) indicates the load limited by hydraulic capacity.

Dimensions & Working Range

R60-9S DIMENSIONS

unit: mm(ft · in)

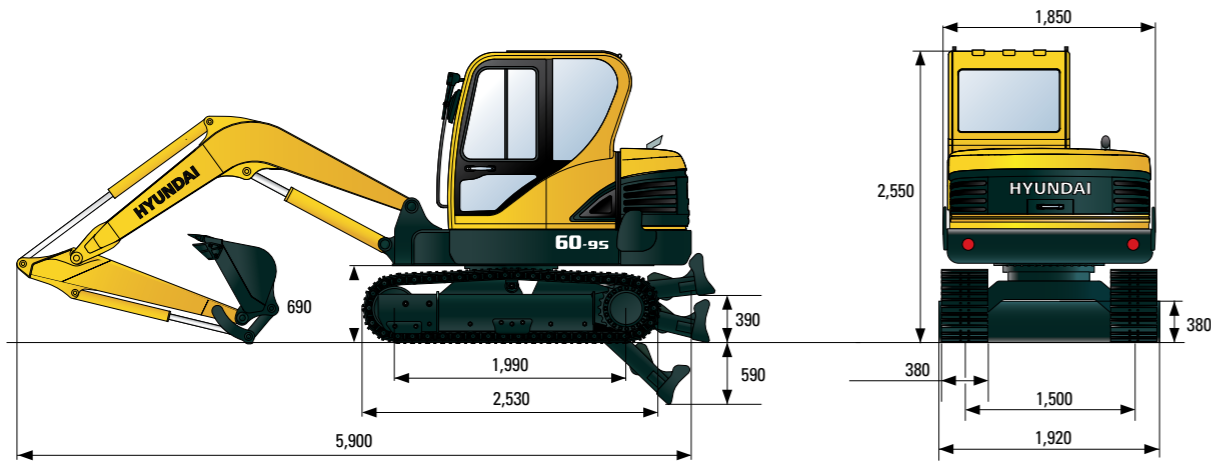

R60-9S WORKING RANGE

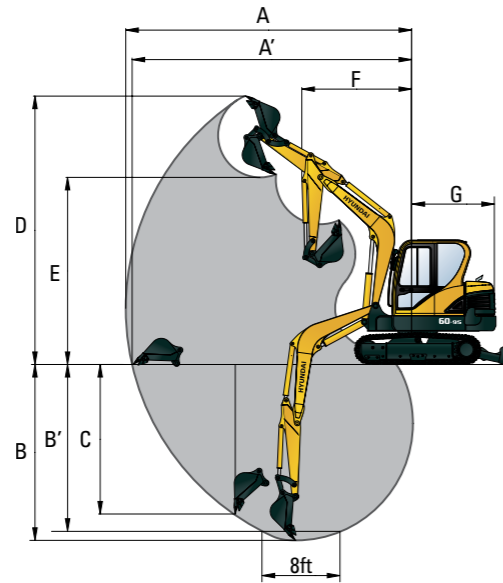

unit: mm

Boom length	3,000	
Arm length	1,600	1,900
A Max. digging reach	6,150	6,400
A' Max. digging reach on ground	6,010	6,270
B Max. digging depth	3,820	4,060
B' Max. digging depth (8ft level)	3,420	3,700
C Max. vertical wall digging depth	3,200	3,460
D Max. digging height	5,780	5,920
E Max. dumping height	4,050	4,180
F Min. swing radius	2,350	2,360
G Tail swing radius	1,650	1,650

STANDARD EQUIPMENT

ISO standard cabin

- Cabin FOPS(ISO 10262 Level I) TOPS(ISO 12117)
- All-weather steel cab with all-around visibility
- Safety glass windows
- Rise-up type windshield wiper
- Sliding fold-in front window
- Sliding side window
- Lockable door
- Accessory box & Ash-tray

Centralized monitoring

- Engine speed
- Gauges
 - Fuel level gauge
 - Engine coolant temperature gauge
- Warning
 - Fuel level

- Engine oil pressure
- Engine coolant temperature
- Hyd. oil temperature
- Low battery
- Air cleaner closing

Door and cab locks, one key

Radio / USB player with remote control

Two outside rear view mirrors

Mechanical suspension seat with heater

Fully adjustable suspension seat with seat belt

Console box tilting system(LH.)

Four front working lights

Electric horn

Battery (1 x 12 V x 100 AH)

Battery master switch

12 volt power supply

Removable clean out screen for radiator

Automatic swing brake

Removable reservoir tank

Water separator, fuel line

Mono fixed boom (3.0 m)

Arm (1.6 m)

Track shoes (380 mm)

Track rail guard

Starting aid (air grid heater) cold weather

Single acting piping kit (breaker, etc)

Viscous fan clutch

OPTIONAL EQUIPMENT

Air-conditioner & heater

Fuel filler pump (35l/min, 9.2 US gpm)

Beacon lamp

Double acting piping kit (clamshell, etc)

4 way acting piping kit (wood grab, etc)

Accumulator, work equipment lowering

Electric transducer

Cabin front (2) and rear (1) work lamp

Travel alarm

Quick coupler

Rubber crawler (400mm)

Long arm (1.9m)

Tool kit

Counter weight (285kg)

(335kg)

Swing boom (3.0 m)

* Standard and optional equipment may vary. Contact your Hyundai dealer for more information. The machine may vary according to International standards.

* The photos may include attachments and optional equipment that are not available in your area.

* Materials and specifications are subject to change without advance notice.

* All imperial measurements rounded off to the nearest pound or inch.