



DURABILITY

- Robust all-around protection cage with solid one-point lift.

COMFORT

- Low levels of hand arm vibration is made possible by the vibration damping solution.

PRACTICAL

- Easy access to daily check points like fuel tank cap, filter.

TECHNICAL DATA

MASSES

Basic mass	88 kg
Operating mass	90 kg

COMPACTION

Frequency	91 Hz
Centrifugal force	14 kN
Amplitude	1.3 mm

TRACTION

Speed	25 m/min
Max. gradeability	18 %
Max. working speed	25 m/min

ENGINE

Manufacturer/Model	Honda GX 160
Emissions according to	EU Stage V & US EPA
Rated power	3.6 kW
Type	Air cooled, Petrol
Number of cylinders	1
Fuel type	Unleaded petrol or alkylate
Fuel consumption /h, avg.	0.65 l
Fuel tank capacity	3.1 l

Find us locally at www.dynapac.com

We reserve the right to change specifications without notice. Photos and illustrations do not always show standard versions of machines. The above information is a general description only, all informations are supplied without liability.



DURABILITY

- Robust all-around protection cage with solid one-point lift.

COMFORT

- Low levels of hand arm vibration is made possible by the vibration damping solution.

PRACTICAL

- Easy access to daily check points like fuel tank cap, filter.

DIMENSIONS

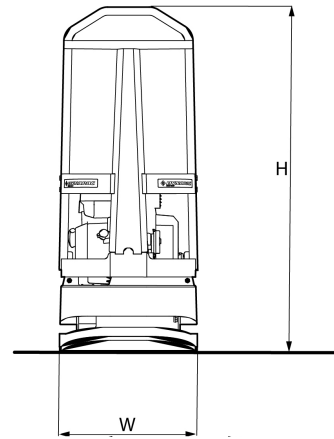
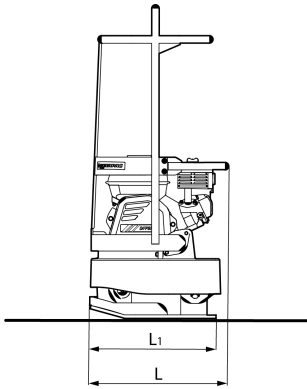

DIMENSIONS

H. Height	1030 mm
L. Length	470 mm
L1. Length	425 mm
W. Basic plate width	430 mm

STANDARD EQUIPMENT

- Control handle -with vibration isolation
- Highly wear resistant base plate
- All around protection for V-belt
- One point lift
- Recoil starter

OPTIONAL EQUIPMENT

- Service Kit

Find us locally at www.dynapac.com

We reserve the right to change specifications without notice. Photos and illustrations do not always show standard versions of machines. The above information is a general description only, all informations are supplied without liability.