



TECHNICAL DATA

MASSES

Basic mass	152 kg
Operating mass	155 kg

COMPACTION

Amplitude	1.3mm
Centrifugal force	25 kN
Frequency	85hz

TRACTION

Max. gradeability	30 %
Max. working speed	25 m/min

DRIVE SYSTEM

Drive system	Mechanical
--------------	------------

ENGINE

Manufacturer/Model	Hatz 1B20
Emissions according to	Stage V
Type	Air cooled diesel
Number of cylinders	1
Fuel tank capacity	3 l
Power	3.1kW@3000rpm
Fuel consumption l /h, avg	0.7 l/h

Find us locally at www.dynapac.com

We reserve the right to change specifications without notice. Photos and illustrations do not always show standard versions of machines. The above information is a general description only, all informations are supplied without liability.



DIMENSIONS

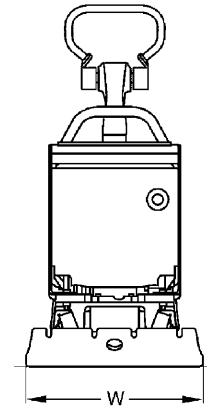
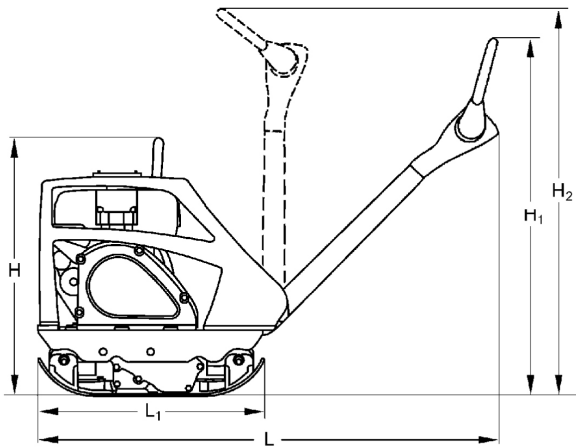

DIMENSIONS

H. Height	740 mm
H1. Height	870 mm
H2. Height	1220 mm
L. Length	1460 mm
L1. Length	650 mm
W. Basic plate width	500 mm

STANDARD EQUIPMENT OPTIONAL EQUIPMENT

- | | |
|--|--|
| <ul style="list-style-type: none"> ■ Control handle with vibration isolation ■ Height adjustable control lever ■ Control lever lock in transport ■ Reverse drive protection ■ All around protection hood ■ Highly wear resistant base plate ■ All around protection for V-belt ■ Automatic decompression | <ul style="list-style-type: none"> ■ Block paving mat ■ Sprinkler system (+13kg) ■ Transport wheels, puncture-proof (+4kg) ■ Service Kit |
|--|--|

Find us locally at www.dynapac.com

We reserve the right to change specifications without notice. Photos and illustrations do not always show standard versions of machines. The above information is a general description only, all informations are supplied without liability.