

BUCKET SELECTION GUIDE

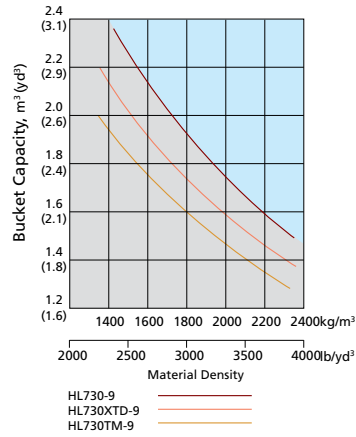

SUPPLEMENTAL SPECIFICATIONS

Description	Change in operating weight kg(lb)	Change in static tipping load-straight kg(lb)	Change in static tipping load-40° turn kg(lb)
17.5-25 12PR L2	-60 (-132)	-43 (-95)	-38 (-84)
17.5 R25 XHA*	+80 (+176)	+57 (+126)	+50 (+110)

STANDARD EQUIPMENT

<p>Electrical system Alternator, 70A Alarms, audible and visual - air filter clogging - transmission error - alternator voltage - brake oil pressure - engine oil pressure - parking brake - fuel level - hydraulic oil temperature - coolant temperature - service brake oil pressure Alarm, back-up Batteries, 850 CCA, 12V, (2) Gauges - engine coolant temperature - fuel level - hydraulic oil temperature - speedometer - transmission oil temperature - voltmeter Horn, electric Indicator lights - clutch cut-off - high beam - turn signal LCD Display - clock and fault code - operating hour counter - engine rpm - transmission gear range</p>	<p>indicator - job time and distance - temperature (coolant, hydraulic oil, T/M oil) Lighting system - LED dome light - 2 stop and tail lights - 4 turn signals - brake lights (counterweight) - 2 head lights on front tower - 2 working lights on front roof - 2 working lights on rear roof Switches - work load - clutch cut-off - hazard - ignition key, start/stop switch - main light (illumination and head light) - parking - rear wiper & washer - work light - battery master switch - pilot cut-off Starter, electric Starting and charging system (24-volt) Cab Cab, ROPS(ISO3471)/FOPS(ISO3449) (sound suppressed and pressurized) with : - cigar lighter & ashtray</p>	<p>- coat hook Automatic climate control - air conditioner & heater - defroster - intermittent wiper and washer, front and rear - personal storage space: holder, can and cup - rear view mirrors (1 inside) - rear view mirrors (2 outside) - 2" retractable seat belt & adjustable suspension seat with armrests - tilt / telescopic steering column - steering wheel with knob - roller type sunshade (front window) - tinted safety glass Magazine pocket Pedals - one accelerator pedal - one brake pedal Rubber floor mat Wrist rest Radio/USB player Engine Antifreeze Engine, Cummins QSB4.5 - low Emission Diesel, Tier-III 3 operating mode - power/standard/econo</p>	<p>Engine enclosure, lockable Engine fuel priming pump Fan guard Fuel/water separator Fuel warmer Muffler, under hood with large exhaust stack Rain cap, engine air intake Radiator (deairation type) Starting aid (air intake heater) Water sensor on fuel filter Power Train Brakes : Service, enclosed wet-disc Parking brake Torque converter Transmission, computer-controlled, electronic soft shift, auto-shift and kick down-shift features included Transmission oil cooler Hydraulics Boom kickout, automatic Bucket positioner, automatic Diagnostic pressure taps Hydraulic system, - 2 spool, single lever, pilot control for boom and bucket actuation Steering, load-sensing Remote cooling fan, hydraulically-driven, temperature sensing type Others</p>	<p>Articulation locking bar Coolant level sight gauge Counterweight Door and cab locks, one key Doors, service access (locking) Drawbar with pin Engine oil level dipstick gauge Ergonomically located and slip resistant, left & right - handrails - ladders - platforms - steps Fenders (front / rear) Guard, bucket cylinder rod Hydraulic oil level sight gauge License plate bracket Lift and tie-down hooks Steering stops, cushioned Tires (17.5-25, 12PR,L3) Transmission oil sight level Vandalism protection caplocks</p>
---	--	---	--	---

OPTIONAL EQUIPMENT

<p>24-volt to 12-volt DC converter Climate control : - air conditioner only - heater only Beacon light, rotating Auxiliary, 2 working lights on front roof (Xenon working lights) Auxiliary, 2 working lights on rear roof 3 piece cutting edge, bolt-on type</p>	<p>Secondary steering system Fire extinguisher High lift arrangement with optional counterweight, 410 kg (904 lb) Hydraulic control, 2 lever Hydraulic control, 3 lever 3rd spool for auxiliary function Joystick with travel switch(FNR) Mud guard Operator suit</p>	<p>Ride control system Heated rear view mirrors (2 outside) Seat - 2" static seat belt & adjustable mechanical suspension(vinyl) - 3" static seat belt & adjustable mechanical suspension - 2" retractable seat belt & adjustable air suspension (heated)</p>	<p>Tires : - 17.5 - 25, 12PR, L2 - 17.5 R25 XHA* Tool kit Tooth, 1 piece, bolt-on type Guards - crankcase - transmission Wheel chock Hi-Mate (Remote Management System)</p>	<p>Rear view camera Dual-brake pedal Roller type sunshade (rear window) License plate & lamp Pre-cleaner engine air intake Limited slip differential</p>
---	---	---	---	--

Standard and optional equipment may vary. Contact your Hyundai dealer for more information. The machine may vary according to International standards. All imperial measurements rounded off to the nearest pound or inch.

PLEASE CONTACT

HYUNDAI CONSTRUCTION EQUIPMENT

Head Office (Sales office)
First tower, 55, Bundang-ro, Bundang-gu, Seongnam-si, Gyeonggi-do, Korea

MOVING YOU FURTHER

HL730-9

With Tier 3 Engine installed



*Photo may include optional equipment.

Pride at Work

Hyundai Heavy Industries strives to build state-of-the-art earthmoving equipment to give every operator maximum performance, more precision, versatile machine preferences, and proven quality. Take pride in your work with Hyundai!



*Photo may include optional equipment.

HL730-9

Machine Walk-Around

Reliable Main Components

Engine Technology

Proven, reliable, fuel efficient, low noise Cummins Tier-III QSB4.5 engine.
Electronically controlled for optimum fuel to air ratio and clean, efficient combustion.
HPCR(High Pressure Common Rail) fuel system / Self-diagnostic system.
Enhanced function of fuel pre-filter / Enhanced reliability of main parts.
3 step(Power / Standard / Economy) operating mode controlled by switch.

Fully Automatic Transmission

4 step(Manual / Light / Normal / Heavy) shift mode by working condition.
Protective transmission at low temperature(Automatic warm-up system).
Self-diagnostic & Memory of malfunction history.
Minimum travel shift shock by applying proportional controlling modulation valve / Self adjusting clutch gap.
Kick-down button & FNR switch for operating comfort.

Axle

Hydraulically lockable front differential front for easy driving on variable ground condition self-adjusting & wheel speed brake.

Improved Durability

Load sensing pump with variable displacement / Closed center type load sensing MCV.
Improved cooling system resistant to thermal shock, impulse and vibration.
Reinforced and welding stress free cast steel steering cylinder lug.

Load Sensing Hydraulic System

Load sensing hydraulic pump technology improves fuel efficiency and reduces energy loss by regulating flow and pressure according to load demand.

Enhanced Operator Comfort

Improved Visibility

Enlarged cab with rounded front center glass.
Good side visibility with newly applied glass on the lower door.
Safety glass windows on all sides.

Improved Convenience

Increased cooling & heating capacity with full auto air-con control.
Tilting & telescopic steering column and adjustable wrist rest to best suit operator preferences.
AM/FM Radio with MP3 interface and USB input and bluetooth hands-free.
Inclined ladder with aluminum die cast steps for easy and safe entry & exit.

Advanced 5.7" Color Monitor

Easy-to-read new color LCD display.
Auto boom kick out and bucket positioner - fully adjustable from within the cab.
Integrated load weighing system, viewable through the monitor, for improved work efficiency and overload prevention.
Self diagnostic & monitoring system with active display of engine, hydraulic system, transmission and electrical component information.
Color, rear-view, back-up camera for improved safety and convenience.

Serviceability

Auto reversing, remote cooling fan for reduced noise and fuel consumption.
Ground level of service points and sight gauges for easy maintenance.
Extended life hydraulic oil filter and oil for reduced operating costs.

Operator Comfort

Operating a 9 series wheel loader is unique to every operator. Operators can fully customize their work environment and operating preferences to fit their individual needs.



*Photo may include optional equipment.

Spacious and Convenient Cab

The newly designed cabin was conceived for more space, a wider field of view and operator comfort. The front glass is rounded and 17% wider than the previous 7A series. Special attention was given to a clean, open and convenient interior with plenty of visibility on the machine surroundings and the job at hand. This well balanced combination of cab ergonomics puts the operator in the perfect position to work safely and securely. The 9 series cab's fully automatic climate control system features 11 air vents and increased cooling and heating capacity for optimum temperature control. The defroster vents located on the front and rear windows and a PTC (electric pre-heater) make working in cold weather more hospitable.



Operator Comfort

In the 9 series cabin you can easily adjust the steering column and wrist rest to best suit your preferred comfort level. Pilot-operated joystick controls are easy and comfortable to operate. An FNR (Forward/Neutral/Reverse) switch on the control lever facilitates easy selection of travel direction. Roller type front sunshades on the front window and rear window allow the operator to reduce glare and improve visibility. Heated side mirrors feature built-in hot wires for quick defrosting during cold weather conditions.



Tilting / telescopic steering column

Reduced Stress

Work is stressful enough. Your work environment should be stress free. Hyundai's 9 series cabin offers lots of amenities, additional space and a comfortable seat to minimize stress to the operator. A powerful climate control system provides the operator with optimum air temperature. An advanced audio system with AM/FM stereo with MP3 interface and USB input, plus remotely located controls is perfect for listening to music favorites.

Advanced Color Monitor



The advanced new monitor with 5.7 inch wide color LCD screen allows the operator to easily and efficiently control the machine. The operator can adjust boom kick-out and bucket position via switches overhead while monitoring the adjustment settings through the monitor. An integrated load weighing system that contributes to improved work efficiency, can also be viewed through the monitor. Self diagnostics, color rear-view camera maintenance check lists and start-up machine security, were integrated into the monitor to make the machine more versatile and the operator more productive. The new monitor display unit is mounted on an adjustable swivel mount to reduce glare and position according to operator preference.

Monitor Tilt Range

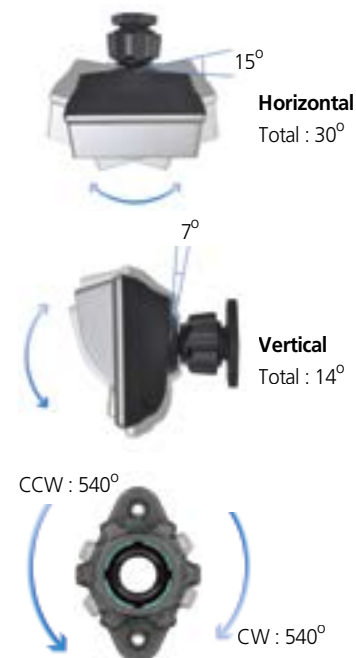

Precision & Performance

Innovative hydraulic system technologies make the 9 series wheel loader fast, smooth and easy to control. 9 series wheel loaders are designed for maximum performance to keep the operator working productively.



Improved Durability & Reliability



An enhanced axle improves driving over variable ground conditions. Self adjusting brakes that automatically regulate disc clearance, reduce service time and improve brake reliability and performance. The new load sensing hydraulic system with a variable volume piston pump and closed center main control valve, provide efficient hydraulic power and additional energy savings. Service and clean-out are easier on the 9 series, now equipped with a completely redesigned, parallel-mounted, cooler configuration and non louvered fins to prevent clogging. All coolers are designed with aluminum bar plate configuration and undergo strict factory tests for thermal shock, impulse and vibration to assure long term durability. A top mounted, non-louvered aluminum air condenser and variable displacement A/C compressor are designed for maximum cooling capacity, energy savings and easy clean-out. Additionally, the redesigned steering cylinder lug is now cast steel for additional strength and reliability.

Variable Operating Modes



9 series wheel loaders are designed to allow the operator to customize the machine's engine power, automatic transmission shift timing and clutch cut-off activation based on the job condition and personal operator preference. Convenient rotary type switches allow for easy adjustment of engine power mode, transmission power shift mode, and clutch cut-off mode. Additionally, if equipped with the optional ride control system, the operator has the option to turn the system on or off with an overhead switch. The ride control system has a shock absorbing accumulator that cushions the boom, improves operator comfort and reduces material loss. The versatility of the 9 series operating modes contributes to improved productivity, enhanced operator comfort and reduced fuel consumption.



3 Mode Engine Power Selection
 P(Power) Mode : Heavy duty work
 S(Standard) Mode : General work
 E(Economy) Mode : Light duty work

4 Mode Transmission Power Shift System
 M(Manual) Mode
 Auto L(Light) Mode : Light duty & long distance carry
 Auto N(Normal) Mode : General excavating & loading
 Auto H(Heavy) Mode : Heavy duty excavating & loading

3 Mode Clutch Cut-Off System
 L(Low) Mode : Short distance & faster loading
 M(Medium) Mode : General loading
 H(High) Mode : Slope ground



Eco-friendly Cummins QSB 4.5 Engine

The Cummins QSB4.5 electronic control engine combines full-authority electronic controls with the reliable performance. The combination of high pressure common rail system and advanced incylinder combustion technology results in increased power, improved transient response and reduced fuel consumption. And the QSB4.5 used advanced electronics controls to meet the emission standards EPA Tier3 and EU Stage III-A.



Fully Automatic Transmission

Fully automatic transmission designed for maximum durability, minimum power loss, improved travel speed and low noise. Improved clutch control and minimized shifting shock when traveling, contribute to a smoother ride. Error messages and transmission fault history are recorded and accessible through the monitor.

*Photo may include optional equipment.

Profitability

The 9 series is designed to maximize profitability through improved efficiencies, enhanced service features and longer life components.



Hi-MATE (Remote Management System)

Hi-MATE, Hyundai's proprietary remote management system, provides operators and dealer service personnel access to vital service and diagnostic information on the machine from any computer with internet access. Users can pinpoint machine location using digital mapping and set machine work boundaries, reducing the need for multiple service calls. Hi-MATE saves time and money for the owner and dealer by promoting preventative maintenance and reducing machine downtime.



Auto-reversing, Remote Cooling Fan

The remote mounted, hydraulically powered cooling fan regulates fan speed according to working temperatures for coolant, intake air, transmission oil and hydraulic oil. This new fan design contributes to reduced fuel consumption and machine noise. The fan is designed to auto reverse periodically or manually reverse to keep debris from accumulating on the coolers.



Easy Access

The engine fan is integrated into the rear door which swings open to over 45 degrees for easy access and regular maintenance. Conveniently located coolant and transmission oil site gauges make checking fluid levels fast and efficient. Ground-line access to fuel and oil filters grease fittings, fuses, machine computer components and wide open compartments makes service more convenient on the 9 series.



Full Fenders and Mud Guards (Option)

9 series wheel loaders can be equipped with optional full rear fenders and front and rear mud flaps to reduce material splatter to the cab and machine frame.



Hydraulic filter
(1,000 hr)



Hydraulic Oil
(5,000 hr)

Extended Life Components

The 9 series is designed for longer lubrication intervals and extended component life. Long life hydraulic filters now have 1,000 hours service intervals and Hyundai certified hydraulic oil can last up to 5,000 hours before changing. Also, a new center pivot roller bearing design, now double tapered, requires less maintenance as well. Long life and extended wear components save the operator time and money.

*Photo may include optional equipment.

Specifications & Dimensions

ENGINE

Maker/Model	CUMMINS QSB4.5
Type	Watercooled, 4-cycle, turbocharged, charge aircooled direct injection, electronic controlled diesel engine
Gross power	125 HP(93 kW) / 2,100rpm
Net power	123 HP(92 kW) / 2,100rpm
Max. power	128 HP(95 kW) / 1,800~2,000rpm
Maximum torque	56 kg.m(408 lb.ft) / 1,400rpm
No. of cylinders	4
Bore x Stroke	107 mm (4.21") x 124 mm (4.88")
Displacement	4.5 l (275 cu in)
Compression ratio	17.2 : 1
Air cleaner	Dry, Two stages dual elements
Alternator	24V, 70 Amp
Battery	2 x 12V, 80 Ah.
Starting motor	24V, 3.7 kW

※ No derating for continuous operating required up to 2,133m (6,998ft). This engine meets the EPA(Tier III) / EU(Stage III-A) Emission regulation.

TRANSMISSION

Torque converter type	3-elements, single-stage single-phase
Tire	17.5-25, L3

※ Full automatic power shift, countershaft type with soft-shift in range and direction. Properly matched torque converter to engine and transmission for excellent working ability.

Travel speed		km/h (mph)
Forward	1st	6.1(3.8)
	2nd	11.2(7.0)
	3rd	22.2(13.8)
	4th	37.2(23.1)
Reverse	1st	6.4(4.0)
	2nd	11.8(7.3)
	3rd	23.4(14.5)

AXLES

Drive system	Four-wheel drive system
Mount	Rigid front axle and oscillating rear axle
Rear axle oscillation	±10° (total 20°)
Hub reduction	Planetary reduction at wheel end
Differential	Conventional
Reduction ratio	22.0

HYDRAULIC SYSTEM

Type	Load-sensing hydraulic system		
Pump	Variable axial piston type, 132 liters/min 34.9 gal/min		
Control valve	2spool (Bucket, Boom) 3spool (Bucket, Boom, Aux) Pilot pressure controlled type System pressure : 250 kgf/cm ² (3.556PSI)		
Bucket Controls	Type	Pilot operated lift and tilt circuit, single-lever(joystick) control standard.	
	Lift Circuit	The valve has four functions ; raise, hold, lower and float. Can adjust automatic kickout from horizontal to full lift.	
	Tilt Circuit	The valve has three functions ; tilt back, hold and dump. Can adjust automatic bucket positioner to desired load angle.	
Cylinders	Type : Double acting No. of cylinders-bore x stroke;		
Lift	HL730-9/730XTD-9/730TM-9	2-ø100 mm x 750 mm(3.9" x 29.5")	
Tilt	HL730-9/730XTD-9 HL730TM-9	ø110 mm x 510 mm(4.3" x 20.1") 2-ø90 mm x 775 mm(3.5" x 30.5")	
Cycle Time	HL730-9 / HL730XTD-9	HL730TM-9	
	Raise(with load)	5.4 sec	5.4 sec
	Dump	1.0 sec	1.4 sec
	Lower(empty)	2.8 sec	2.8 sec
	Total	9.2 sec	9.6 sec

AIR CONDITIONING SYSTEM

The air condition system for the machine contains the fluorinated greenhouse gas with global warming potential of R134a. (Global Warming Potential : 1430)
The system hold 0.75kg refrigerant consisting of a CO₂ equivalent 1.07kg metric tonne. For more information, Please refer to the manual.

BRAKES

Service Brakes	Hydraulically actuated, wet disc brakes actuate all 4 wheels independent axle-by-axle system Self adjusting & in board brake
Parking Brake	Spring-applied, hydraulically released brake in Front Axle
Emergency Brake	When brake oil pressure drops, indicator light alerts operator and parking brake automatically applies.

SERVICE REFILL CAPACITIES

Fuel tank	200 liters (52.8 USgal)
Cooling system	30 liters (7.9 USgal)
Crankcase	11 liters (2.9 USgal)
Transmission	20 liters (5.3 USgal)

OVERVIEW

Description	UNIT	HL730-9	HL730XTD-9	HL730TM-9
Operating weight	kg (lb)	9,800 (21,600)	10,000 (22,050)	10,200 (22,500)
Bucket capacity	Heaped	m ³ (yd ³) 1.9 (2.5)	1.9 (2.5)	1.7 (2.2)
	Struck	m ³ (yd ³) 1.6 (2.1)	1.6 (2.1)	1.45 (1.9)
Breakout force-bucket	kg (lb)	9,150 (20,170)	9,070 (20,000)	9,960 (21,960)
Tipping load	Straight	kg (lb) 7,900 (17,420)	7,120 (15,700)	6,750 (14,880)
	Full turn	kg (lb) 6,900 (15,210)	6,130 (13,510)	5,800 (12,790)

DIMENSIONS

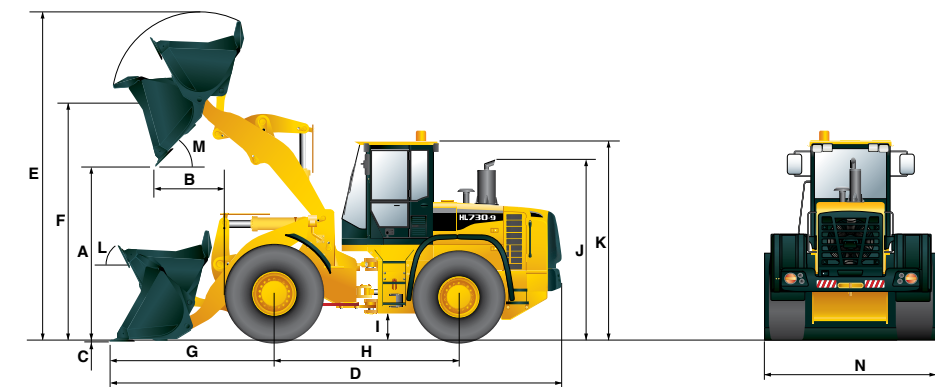

Description	UNIT	HL730-9	HL730XTD-9	HL730TM-9
Bucket Type	General purpose bolt-on cutting edge			
A. Dumping clearance at max. height and 45° dump angle.	mm (ft-in)	2,700 (8' 10")	3,035 (9' 11")	2,785 (9' 2")
B. Reach	Full lift	mm (ft-in) 1,040 (3' 5")	1,010 (3' 4")	1,130 (3' 8")
	7ft height	mm (ft-in) 1,470 (4' 10")	1,730 (5' 8")	1,600 (5' 3")
C. Digging depth	mm (in)	103 (4.1")	117 (4.6")	95 (3.7")
D. Overall length	on ground	mm (ft-in) 6,950 (22' 10")	7,240 (23' 9")	7,060 (23' 2")
	at carry	mm (ft-in) 6,895 (22' 7")	7,205 (23' 8")	6,870 (22' 6")
E. Overall height (fully raised)	mm (ft-in)	4,850 (15' 11")	5,190 (17')	4,900 (16' 1")
F. Bucket pivot max. height	mm (ft-in)	3,640 (11' 11")	3,980 (13' 1")	3,795 (12' 5")

STEERING SYSTEM

Type	Load-sensing hydrostatic articulated steering	
Pump	Piston pump, 132 l/min (34.9 gal/min)@governed rpm	
Relief Valve Setting	210 kg/cm ² (2,986 psi)	
Cylinder	Type	Double acting
	Bore x Stroke	60mm x 412mm(2.4" x 16.2")
Steering Angle	40°(each direction)	

Features
- Center-point frame articulation. - Tilt and telescopic steering column.

Front axle	17.7 liters (4.7 USgal)
Rear axle	17.7 liters (4.7 USgal)
Hydraulic tank	121 liters (32.0 USgal)
Hydraulic system (including tank)	154 liters (40.7 USgal)

TIRES

Type	Tubeless, loader design tires
Standard	17.5-25, 12 PR, L3
Options include	17.5-25, 12 PR, L2 17.5 R25 XHA*

Description	UNIT	HL730-9	HL730XTD-9	HL730TM-9
G. Front overhang	mm (ft-in)	2,365 (7' 9")	2,655 (8' 9")	2,470 (8' 1")
H. Wheelbase	mm (ft-in)	2,750 (9')	2,750 (9')	2,750 (9')
I. Ground clearance	mm (ft-in)	370 (1' 3")	370 (1' 3")	370 (1' 3")
J. Height over exhaust	mm (ft-in)	3,010 (9' 11")	3,010 (9' 11")	3,010 (9' 11")
K. Height over cab	mm (ft-in)	3,170 (10' 5")	3,170 (10' 5")	3,170 (10' 5")
L. Roll-back angle	on ground	deg	42	50
	at carry	deg	47	54
M. Dump angle	deg	48	48	50
Clearance circle	mm (ft-in)	11,020 (36' 2")	11,300 (37' 1")	11,100 (36' 5")
N. Overall width	mm (ft-in)	2,450 (8')	2,450 (8')	2,400 (7' 10")